ELECTRICAL MOTOR-GENERATOR GB2282708

DATE OF A PUBLICATION: 12.04.1995

Applicant(s):

Harold Aspden - SOUTHAMPTON, United Kingdom
Robert George Adams - New Zealand

Date of Filing: 30.09.1993

Application No: 9320215.8

INTeL⁶:

HO2K 29/0823/5223/66/I HO2K 1/27

UKCL(Edition N):

H2A AKC2 AKR 1 AK1O8 AK12O AK12 1 AK200 AK214R AK2 165 AK217R AK3O2B AK3O3R AK800

Documents Cited:

GB 0547608 A US 5258697 A US 4972112 A US 4873463 A

Field of Search:

UK CL (Edition M) H2A AKRR AKR1 AKR6 AKR9
INT CL⁵ HO2K 23/62 29/08 29/10 29/12 53/00 57/00
ONLINE DATABASES : WPI. CLAIMS

Agent and/or Address for Service:

Harold Aspden, SOUTHAMPTON, United Kingdom

ABSTRACT

An electrodynamic motor-generator has a salient pole permanent magnet rotor interacting with salient stator poles to form a machine operating on the magnetic reluctance principle. The intrinsic ferromagnetic power of the magnets provides the drive torque by bringing the poles into register whilst current pulses demagnetize the stator poles as the poles separate. In as much as less power is needed for stator demagnetization than is fed into the reluctance drive by the thermodynamic system powering the ferromagnetic state, the machine operates regeneratively by virtue of stator winding interconnection with unequal number of rotor and stator poles. A rotor construction is disclosed (Fig 6, 7). The current pulse may be such as to cause repulsion of the rotor poles.

FIELD OF INVENTION

This invention relates to a form of electric motor which serves a generating function in that the machine can act regeneratively to develop output electrical power or can generate mechanical

drive torque with unusually high efficiency in relation to electrical power input.

The field of invention is that of switched reluctance motors, meaning machines which have salient poles and operate by virtue of the mutual magnetic attraction and / or repulsion as between magnetized poles. The invention particularly concerns a form of reluctance motor which incorporates permanent magnets to establish magnetic polarization.

BACKGROUND OF THE INVENTION

There have been proposals in the past for machines in which the relative motion of magnets can in some way develop unusually strong force actions which are said to result in more power output than is supplied as electrical input.

By orthodox electrical engineering principles such suggestions have seemed to contradict accepted principles of physics, but it is becoming increasingly evident that conformity with the first law of thermodynamics allows a gain in the electromechanical power balance provided it is matched by a thermal cooling.

In this sense, one needs to extend the physical background of the cooling medium to include, not just the machine structure and the immediate ambient environment, but also the sub-quantum level of what is termed, in modern physics, the zero-point field. This is the field associated with the Planck constant. Energy is constantly being exchanged as between that activity and coextensive matter forms but normally these energy fluctuations preserve, on balance, an equilibrium condition so that this action passes unnoticed at the technology level.

Physicists are becoming more and more aware of the fact that, as with gravitation, so magnetism is a route by which we can gain access to the sea of energy that pervades the vacuum. Historically, the energy balance has been written in mathematical terms by assigning 'negative' potential to gravitation or magnetism. However, this is only a disguised way of saying that the vacuum field, suitably influenced by the gravitating mass of a body in the locality or by magnetism in a ferromagnet has both the capacity and an urge to shed energy.

Now, however, there is growing awareness of the technological energy generating potential of this field background and interest is developing in techniques for 'pumping' the coupling between matter and vacuum field to derive power from that hidden energy source. Such research may establish that this action will draw on the 2.7K cosmic background temperature of the space medium through which the Earth travels at some 400 km/s. The effect contemplated could well leave a cool vapour trail' in space as a machine delivering heat, or delivering a more useful electrical form of energy that will revert to heat, travels with body Earth through that space.

In pure physics terms, relevant background is of recent record in the August 1993 issue of Physical Review E, vol. 48, pp. 1562-1565 under the title: 'Extracting energy and heat from the vacuum', authored by D.C. Cole and H. E. Puthoff. Though the connection is not referenced in that paper, one of its author's presented experimental evidence on that theme at an April 1993 conference held in Denver USA. The plasma power generating device discussed at that conference was the subject of U. S. Patent No. 5,018,180, the inventor of record being K. R. Shoulders.

The invention, to be described below, operates by extracting energy from a magnetic system in a motor and the relevant scientific background to this technology can be appreciated from the teachings of E.B. Moullin, a Cambridge Professor of Electrical Engineering who was a President of the Institution of Electrical Engineers in U. K.

That prior art will be described below as part of the explanation of the operation of the invention.

The invention presented here concerns specific structural design features of a machine adapted for robust operation, but these also have novelty and special merit in a functional operation. What is described is quite distinct from prior art proposals, one being a novel kind of motor proposed by Gareth Jones at a 1988 symposium held in Hull, Canada under the auspices of the Planetary Association for Clean Energy. Jones suggested the adaptation of an automobile alternator which generates three-phase a. c. for rectification and use as a power supply for the electrics in the automobile. This alternator has a permanent magnet rotor and Jones suggested that it could be used, with high efficiency gain and torque performance, by operating it as a motor with the three-phase winding circuit excited so as to promote strong repulsion between the magnet poles and the stator poles after the poles had come into register. However, the Jones machine is not one exploiting the advantages of the invention to be described, because it is not strictly a reluctance motor having salient poles on both stator and rotor. The stator poles in the Jones machine are formed by the winding configuration in a slotted stator form, the many slots being uniformly distributed around the inner circumference of the stator and not constituting a pole system which lends itself to the magnetic flux actions to be described by reference to the E.B. Moullin experiment.

The Jones machine operates by generating a rotating stator field which, in a sense, pushes the rotor poles forward rather than pulling them in the manner seen in the normal synchronous motor. Accordingly, the Jones machine relies on the electric current excitation of the motor producing a field system which rotates smoothly but has a polarity pattern which is forced by the commutation control to keep behind the rotor poles in asserting a continuous repulsive drive.

Another prior art proposal which is distinguished from this invention is that of one of the applicants, H. Aspden, namely the subject of U.K. Patent No. 2,234,863 (counterpart U.S. Patent Serial No. (4,975,608)). Although this latter invention is concerned with extracting energy from the field by the same physical process as the subject invention, the technique for accessing that energy is not optimum in respect of the structure or method used. Whereas in this earlier disclosure, the switching of the reluctance drive excited the poles in their approach phase, the subject invention, in one of its aspects, offers distinct advantages by demagnetization or reversal of magnetization in the pole separation phase of operation.

There are unexpected advantages in the implementation proposed by the subject invention, inasmuch as recent research has confirmed that it requires less input power to switch off the mutual attraction across an air gap between a magnet and an electromagnet than it does to switch it on. Usually, in electromagnetism, a reversal symmetry is expected, arising from conventional teaching of the way forward and back magnetomotive forces govern the resulting flux in a magnetic circuit. This will be further explained after describing the scope of the invention.

BRIEF DESCRIPTION OF THE INVENTION

According to one aspect of the invention, an electrodynamic motor-generator machine comprises a stator configured to provide a set of stator poles, a corresponding set of magnetizing windings mounted on the stator pole set, a rotor having two sections each of which has a set of salient pole pieces, the rotor sections being axially spaced along the axis of rotation of the rotor, rotor magnetization means disposed between the two rotor sections arranged to produce a unidirectional magnetic field which magnetically polarizes the rotor poles, whereby the pole faces of one rotor section all have a north polarity and the pole faces of the other rotor section all have a south polarity and electric circuit connections between an electric current source and the stator magnetizing windings arranged to regulate the operation of the machine by admitting current pulses for a duration determined according to the angular position of the rotor, which pulses have a direction tending to oppose the polarization induced in the stator by the rotor polarization as stator and rotor poles separate from an in-register position, whereby the action of the rotor magnetization means provides a reluctance motor drive force to bring stator and rotor poles into register and the action of the stator magnetization windings opposes the counterpart reluctance braking effect as the poles separate.

According to a feature of the invention, the circuit connecting the electric current source and the stator magnetizing windings is designed to deliver current pulses which are of sufficient strength and duration to provide demagnetization of the stator poles as the stator and rotor poles separate from an in-register position. In this regard it is noted that in order to suppress the reluctance drive torque or brake torque, depending upon whether poles are converging or separating, a certain amount of electrical power must be fed to the magnetizing windings on the stator. In a sense these windings are really 'demagnetizing windings' because the polarity of the circuit connections admit the pulse current in the demagnetizing direction. However, it is more usual to refer to windings on magnetic cores as 'magnetizing windings' even though they can function as primary windings or secondary windings, the former serving the magnetization function with input power and the latter serving a demagnetizing function with return of power.

According to another feature of the invention, the circuit connecting the electric current source and the stator magnetizing windings is designed to deliver current pulses which are of sufficient strength and duration to provide a reversal of magnetic flux direction in the stator poles as the stator and rotor poles separate from an in-register position, whereby to draw on power supplied from the electric current source to provide additional forward drive torque.

According to a further feature of this invention, the electric current source connected to stator magnetizing winding of a first stator pole comprises, at least partially, the electrical pulses induced in the stator magnetizing winding of a different second stator pole, the stator pole set configuration in relation to the rotor pole set configuration being such that the first stator pole is coming into register with a rotor pole as the second stator pole separates from its in register position with a rotor pole.

This means that the magnetizing windings of two stator poles are connected so that both serve a 'demagnetizing' function, one in resisting the magnetic action of the mutual attraction in pulling poles into register, an action which develops a current pulse output and one in absorbing this current pulse, again by resisting the magnetic inter-pole action to demagnetize the stator pole as its associated rotor pole separates.

In order to facilitate the function governed by this circuit 10 connection between stator magnetizing windings, a phase difference is needed and this is introduced by designing the machine to have a different number of poles in a set of stator poles from the number of rotor poles in each rotor section. Together with the dual rotor section feature, this has the additional merit of assuring a smoother torque action and reducing magnetic flux fluctuations and leakage effects which contribute substantially to machine efficiency.

Thus, according to another feature of the invention, the stator configuration provides pole pieces which are common to both rotor sections in the sense that when stator and rotor poles are in-register the stator pole pieces constitute bridging members for magnetic flux closure in a magnetic circuit including that of the rotor magnetization means disposed between the two rotor sections.

Preferably, the number of poles in a set of stator poles and the number of rotor poles in each section do not share a common integer factor, the number of rotor poles in one rotor section is the same as that in the other rotor section and the number of poles in a stator set and the number of poles in a rotor section differs by one, with the pole faces According to a further feature of the invention, the electric current source connected to a stator magnetizing winding of a first stator pole comprises, at least partially, the electrical pulses induced in the stator magnetizing winding of a different second stator pole, the stator pole set configuration in relation to the rotor pole set configuration being such that the first stator pole is coming into register with a rotor pole as being of sufficient angular width to assure that the magnetic flux produced by the rotor magnetization means can find a circuital magnetic flux closure route through the bridging path of a stator pole and through corresponding rotor poles for any angular position of the rotor.

It is also preferable from a design viewpoint for the stator pole faces of this invention to have an angular width that is no greater than half the angular width of a rotor pole and for the rotor sections to comprise circular steel laminations in which the rotor poles are formed as large teeth at the perimeter with the rotor magnetization means comprising a magnetic core structure the end faces of which abut two assemblies of such laminations forming the two rotor sections.

According to a further feature of the invention, the rotor magnetization means comprises at least one permanent magnet located with its polarization axis parallel with the rotor axis. The motor-generator may include an apertured metal disc that is of a non-magnetizable substance mounted on a rotor shaft and positioned intermediate the two rotor sections, each aperture providing location for a permanent magnet, whereby the centrifugal forces acting on the permanent magnet as the rotor rotates are absorbed by the stresses set up in the disc. Also, the rotor may be mounted on a shaft that is of a non-magnetizable substance, whereby to minimize magnetic leakage from the rotor magnetizing means through that shaft.

According to another aspect of the invention, an electrodynamic motor-generator machine comprises a stator configured to provide a set of stator poles, a corresponding set of magnetizing windings mounted on the stator pole set, a rotor having two sections each of which has a set of salient pole pieces, the rotor sections being axially spaced along the axis of rotation of the rotor, rotor magnetization means incorporated in the rotor structure and arranged to polarize the rotor poles, whereby the pole faces of one rotor section all have a north polarity and the pole faces of the other rotor section all have a south polarity and electric circuit connections between an electric current source and the stator magnetizing windings

arranged to regulate the operation of the machine by admitting current pulses for a duration determined according to the angular position of the rotor, which pulses have a direction tending to oppose the polarization induced in the stator by the rotor polarization as stator and rotor poles separate from an in-register position, whereby the action of the rotor magnetization means provides a reluctance motor drive force to bring stator and rotor poles into register and the action of the stator magnetization windings opposes the counterpart reluctance braking effect as the poles separate.

According to a feature of this latter aspect of the invention, the electric current source connected to a stator magnetizing winding of a first stator pole comprises, at least partially, the electrical pulses induced in the stator magnetizing winding of a different second stator pole, the stator pole set configuration in relation to the rotor pole set configuration being such that the first stator pole is coming into register with a rotor pole as the second stator pole separates from its in-register position with a rotor pole.

BRIEF DESCRIPTION OF THE DRAWINGS

Fig. 1 presents magnetic core test data showing how the volt-amp reactance power required to set up a constant magnetic flux action in an air gap, as assured by constant a. c. voltage excitation of a magnetizing winding, falls short of the associated power of the potential implicit in the force action across that air gap.

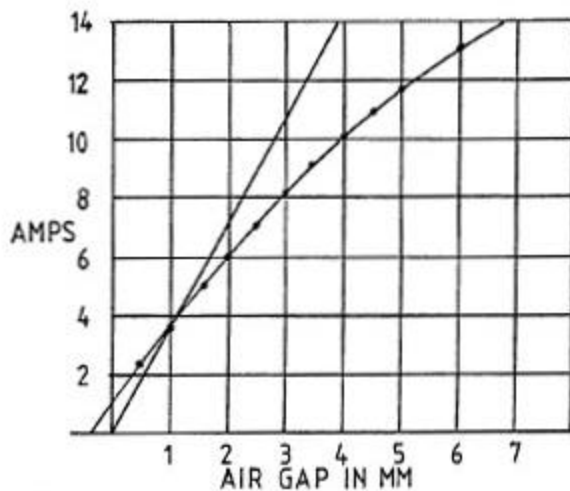

FIG.1

Fig. 2 depicts the test structure to which Fig. 1 data applies.

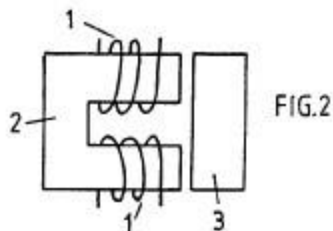

Fig. 3 depicts the magnetization action at work in causing magnetic flux to traverse an airgap and turn a corner in a circuit through a magnetic core.

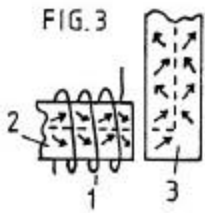

Fig. 4 shows the configuration of a test device used to prove the operating principles of the

invention described.

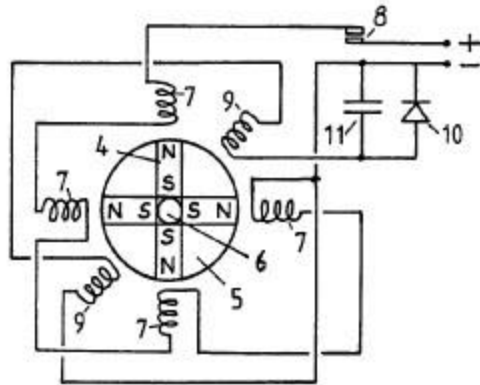

FIG. 4

Fig. 5 in its several illustrations depicts the progressive rotor pole to stator pole relationship as a rotor turns through a range of angular positions in a preferred embodiment of a machine according to the invention.

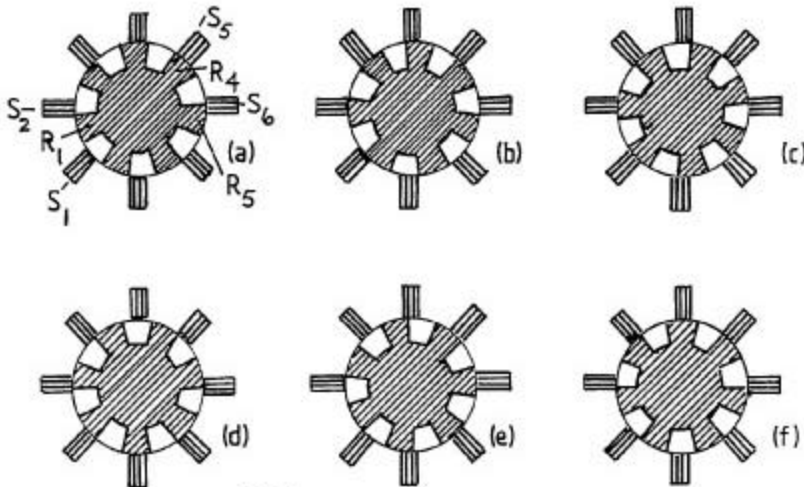

FIG. 5

Fig. 6 shows the form of a disc member which provides location for four permanent magnets in the machine described.

FIG. 6

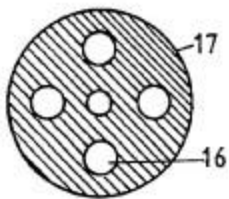

Fig. 7 shows a cross-section of the magnetic circuit structure of a machine embodying the invention.

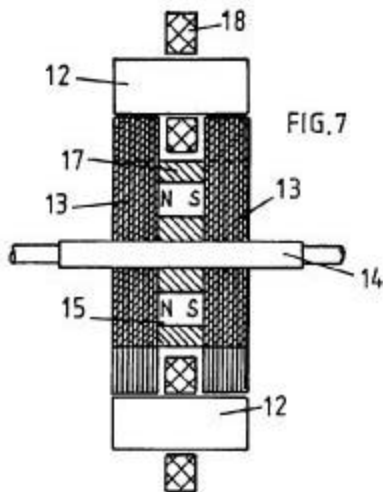
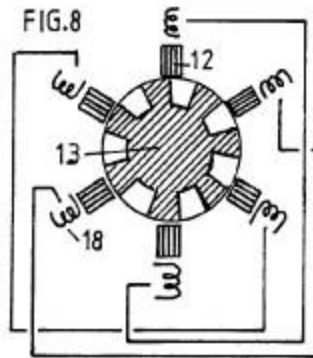

Fig. 8 shows a six stator pole configuration with a seven pole rotor and depicts a schematic series connected linking of the magnetizing windings of diametrically opposite stator poles.



DETAILED DESCRIPTION OF THE INVENTION

The fact that one can extract energy from the source which powers the intrinsic ferromagnetic state is not explicitly evident from existing textbooks, but it is implicit and, indeed, does become explicit once pointed out, in one textbook authored by F. B. Moullin.

His book *'The Principles of Electromagnetism'* published by Clarendon Press, Oxford (3rd Edition, 1955) describes on pages 168-174 an experiment concerned with the effect of air gaps between poles in a magnetic circuit. The data obtained are reproduced in Fig. 1, where Professor Moullin shows a curve representing a. c. current input for different air gaps, given that the voltage supplied is constant. In the same figure, Moullin presents the theoretical current that would need to be applied to sustain the same voltage, and so the related pole forces across the air gap, assuming (a) no flux leakage and (b) that there is complete equality between inductive energy input and the mechanical energy potential for the magnetization that is established in the air gap in a quarter-cycle period at the a. c. power excitation frequency.

The data show that, even though the level of magnetic polarization is well below the saturation value, being confined to a range that is regarded as the linear permeability range in transformer design, there is a clear drop-off of current, and so the volt-amp reactive power input needed, as current increases, compared with that predicted by the mechanical potential

built up in the air gaps.

Unless leakage flux is excessive, here was clear evidence of anomalous energy activity.

Moullin discusses the leakage flux inferred by this experiment but points out that there is considerable mystery in why the effect of a small gap, which should certainly not result in much flux leakage in the gap region, nevertheless has an enormous effect in causing what has to be substantial leakage in the light of the energy discrepancy.

Moullin did not contemplate that energy had been fed in from the zero-point field system and so he left the issue with the statement that it was virtually impossible to predict leakage flux by calculation.

He was, of course, aware of magnetic domain structure and his argument was that the leakage flux problem was connected with what he termed a 'yawing' action of the flux as it passes around the magnetic circuit. Normally, provided the level of polarization is below the knee of the B-H curve, which occurs at about 70% of saturation in iron cores of general crystal composition, it requires very little magnetizing field to change the magnetic flux density. This is assuming that every effort is made to avoid air gaps. The action involves domain wall movements so that the magnetic states of adjacent domains switch to different crystal axes of easy magnetization and this involves very little energy change.

However, if there is an air gap ahead in the flux circuit and the magnetizing winding is not sitting on that air gap, the iron core itself has to be the seat of a progressive field source linking the winding and the gap. It can only serve in that sense by virtue of the lines of flux in the domains being forced to rotate somewhat from the preferred easy axes of magnetization, with the help of the boundary surfaces around the whole core. This action means that, forcibly, and consequential upon the existence of the air gap, the flux must be carried through the core by that 'yawing' action. It means that substantial energy is needed to force the establishment of those fields within the iron core. More important, however, from the point of view of this invention, it means that the intrinsic magnetic polarization effects in adjacent magnetic domains in the iron cease to be mutually parallel or orthogonal so as to stay directed along axes of easy magnetization. Then, in effect, the magnetizing action is not just that of the magnetizing winding wrapped around the core but becomes also that of adjacent ferromagnetic polarization as the latter act in concert as vacuum-energy powered solenoids and are deflected into one another to develop the additional forward magnetomotive forces.

The consequences of this are that the intrinsic ferromagnetic power source with its thermodynamic ordering action contributes to doing work in building up forces across the air gap. The task, in technological terms, is then to harness that energy as the gap is closed, as by poles coming together in a reluctance motor, and avoid returning that energy as the poles separate, this being possible if the controlling source of primary magnetization is well removed from the pole gap and the demagnetization occurs when the poles are at the closest position.

This energy situation is evident in the Moullin data, because the constant a. c. voltage implies a constant flux amplitude across the air gap if there is no flux leakage in the gap region. A constant flux amplitude implies a constant force between the poles and so the gap width in relation to this force is a measure of the mechanical energy potential of the air gap. The reactive volt-amp power assessment over the quarter-cycle period representing the polarization demand can then be compared with the mechanical energy so made available. As

already stated, this is how Moullin deduced the theoretical current curve. In fact, as his data show, he needed less current than the mechanical energy suggested and so he had in his experiment evidence of the vacuum energy source that passed unnoticed and is only now revealing itself in machines that can serve our energy needs.

In the research leading to this patent application the Moullin experiment has been repeated to verify a condition where a single magnetizing winding serves three air gaps. The Moullin test configuration is shown in Fig. 2, but in repeating the experiment in the research leading to this invention, a search coil was mounted on the bridging member and this was used to compare the ratio of the voltage applied to the magnetizing winding and that induced in the search coil. The same fall-off feature in current demand was observed, and there was clear evidence of substantial excess energy in the air gap. This was in addition to the inductive energy that necessarily had to be locked into the magnetic core to sustain the 'yawing' action of the magnetic flux already mentioned.

It is therefore emphasized that, in priming the flux 'yawing' action, energy is stored inductively in the magnetic core, even though this has been deemed to be the energy of flux leakage outside the core. The air gap energy is also induction energy. Both energies are returned to the source winding when the system is demagnetized, given a fixed air gap. If, however, the air gap closes after or during magnetization, much of that inductive energy goes into the mechanical work output. Note then that the energy released as mechanical work is not just that stored in the air gap but is that stored in sustaining the 'yaw'. Here, then is reason to expect an even stronger contribution to the dynamic machine performance, one that was not embraced by the calculation of the steady-state situation.

Given the above explanation of the energy source, the structural features which are the subject of this invention will now be described.

The 'yawing' action is depicted in Fig. 3, which depicts how magnetic flux navigates a right-angled bend in a magnetic core upon passage through an air gap. By over-simplification it is assumed that the core has a crystal structure that has a preferred axis of magnetization along the broken line path. With no air gap, the current needed by a magnetizing winding has only to provide enough magnetomotive force to overcome the effects of non-magnetic inclusions and impurities in the core substance and very high magnetic permeabilities can apply. However, as soon as the air gap develops, this core substance has to find a way of setting up magnetomotive force in regions extending away from the locality of the magnetizing winding. It cannot do this unless its effect is so powerful that the magnetic flux throughout the magnetic circuit through the core substance is everywhere deflected from alignment with a preferred easy axis of magnetization. Hence the flux vectors depicted by the arrows move out of alignment with the broken line shown.

There is a 'knock-on' effect progressing all the way around the core from the seat of the magnetizing winding and, as already stated, this harnesses the intrinsic ferromagnetic power that, in a system with no air gap, could only be affected by magnetization above the knee of the B-H curve. Magnetic flux rotation occurs above that knee, whereas in an ideal core the magnetism develops with very high permeability over a range up to that knee, because it needs very little power to displace a magnetic domain wall sideways and promote a 90° (Degree) or a 180° (Degree) flux reversal. Indeed, one can have a magnetic permeability of 10,000 below the knee and 100 above the knee, the latter reducing progressively until the substance saturates magnetically.

In the situation depicted in Figs 2 or 3 the field strength developed by the magnetizing windings **1** on magnetic core **2** has to be higher, the greater the air gap, in order to achieve the same amount of magnetization as measured by the voltage induced in a winding (not shown) on the bridging member **3**. However, by virtue of that air gap there is potential for harnessing energy supplied to that air gap by the intrinsic zero-point field that accounts for the magnetic permeability being over unity and here one can contemplate very substantial excess energy potential, give incorporation in a machine design which departs from convention.

One of the applicants has built an operative test machine which is configured as depicted schematically in Fig. 4. The machine has been proved to deliver substantially more mechanical power output than is supplied as electrical input, as much as a ratio of 7:1 in one version, and it can act regeneratively to produce electrical power.

What is shown in Fig. 4 is a simple model designed to demonstrate the principle of operation. It comprises a rotor in which four permanent magnets **4** are arrayed to form four poles. The magnets are bonded into four sectors of a non-magnetic disc **5** using a high density polyurethane foam filler and the composite disc is then assembled on a brass spindle **6** between a split flange coupling. Not shown in the figure is the structure holding the spindle vertically in bearings or the star wheel commutator assembly attached to the upper shaft of the spindle.

Note that the magnets present north poles at the perimeter of the rotor disc and that the south poles are held together by being firmly set in the bonding material.

A series of four stator poles were formed using magnetic cores from standard electromagnetic relays are were positioned around the rotor disc as shown. The magnetizing windings **7** on these cores are shown to be connected in series and powered through commutator contacts **8** by a d. c. power supply. Two further stator cores formed by similar electromagnetic relay components are depicted by their windings **9** in the intermediate angle positions shown and these are connected in series and connected to a rectifier **10** bridged by a capacitor **11**.

The rotor spindle **6** is coupled with a mechanical drive (not shown) which harnesses the torque developed by the motor thus formed and serves as a means for measuring output mechanical power delivered by the machine.

In operation, assuming that the rotor poles are held initially off-register with the corresponding stator poles and the hold is then released, the strong magnetic field action of the permanent magnets will turn the rotor to bring the stator and rotor poles into register. A permanent magnet has a strong attraction for soft iron and so this initial impulse of rotation is powered by the potential energy of the magnets.

Now, with the rotor acting as a flywheel and having inertia it will have a tendency to over-shoot the in-register pole position and that will involve a reverse attraction with the result that the rotor will oscillate until damping action brings it to rest. However, if the contacts of the commutating switch are closed as the poles come first into register, the magnetizing windings **7** will receive a current pulse which, assuming the windings are connected in the right sense, tends to demagnetize the four stator cores. This means that, as the stator and rotor poles separate, the reverse attraction by the magnets is eliminated. Indeed, if the demagnetizing current pulses supplied to the windings **4** are strong enough, the stator poles can reverse polarity and that results in a repulsion giving forward drive to the separating rotor poles.

The net result of this action is that the rotor will continue rotating until it passes the dead centre angular position which allows the rotor to be attracted in the forward direction by the stator poles 90° (Degree) forward of those acting originally.

The commutating switch **8** needs only to be closed for a limited period of angular travel following the top dead centre in-register position of the stator and rotor poles. The power supplied through that switch by those pulses will cause the rotor to continue rotating and high speeds will be achieved as the machine develops its full motor function.

Tests on such a machine have shown that more mechanical power can be delivered than is supplied electrically by the source powering the action through the commutating switch. The reason for this is that, whereas the energy in the air gap between rotor and stator poles which is tapped mechanically as the poles come into register is provided by the intrinsic power of the ferromagnet, a demagnetizing winding on the part of the core system coupled across that air gap needs very little power to eliminate the mechanical force acting across that air gap. Imagine such a winding on the bridging member shown in Fig. 2. The action of current in that winding, which sits astride the 'yawing' flux in that bridging member well removed from the source action of the magnetizing windings **1**, is placed to be extremely effective in resisting the magnetizing influence communicated from a distance. Hence very little power is needed to overcome the magnetic coupling transmitted across the air gap.

Although the mutual inductance between two spaced-apart magnetizing windings has a reciprocal action, regardless of which winding is primary and which is secondary, the action in the particular machine situation being described involves the 'solenoidal' contribution represented by the 'yawing' ferromagnetic flux action. The latter is not reciprocal inasmuch as the flux 'yaw' depends on the geometry of the system. A magnetizing winding directing flux directly across an air gap has a different influence on the action in the ferromagnetic core from one directing flux lateral to the air gap and there is no reciprocity in this action.

In any event, the facts of experiment do reveal that, owing to a significant discrepancy in such mutual interaction, more mechanical power is fed into the rotor than is supplied as input from the electrical source.

This has been further demonstrated by using the two stator windings **9** to respond in a generator sense to the passage of the rotor poles. An electrical pulse is induced in each winding by the passage of a rotor pole and this is powered by the inertia of the rotor disc **5**. By connecting the power so generated to charge the capacitor **11** the d. c. power supply can be augmented to enhance the efficiency even further. Indeed, the machine is able to demonstrate the excess power delivery from the ferromagnetic system by virtue of electrical power generation charging a battery at a greater rate than a supply battery is discharged.

This invention is concerned with a practical embodiment of the motor-generator principles just described and aims, in its preferred aspect, to provide a robust and reliable machine in which the tooth stresses in the rotor poles, which are fluctuating stresses communicating high reluctance drive torque, are not absorbed by a ceramic permanent magnet liable to rupture owing to its brittle composition.

Another object is to provide a structure which can be dismantled and reassembled easily to replace the permanent magnets, but an even more important object is that of minimizing the stray leakage flux oscillations from the powerful permanent magnets. Their rotation in the

device depicted in Fig. 4 would cause excessive eddy-current induction in nearby metal, including that of the machine itself, and such effects are minimized if the flux changes are confined to paths through steel laminations and if the source flux from the magnets has a symmetry or near symmetry about the axis of rotation.

Thus, the ideal design with this in mind is one where the permanent magnet is a hollow cylinder located on a non-magnetic rotor shaft, but, though that structure is within the scope of this invention, the machine described will utilize several separate permanent magnets approximating, in function, such a cylindrical configuration.

Referring to Fig. 4, it will further be noted that the magnetic flux emerging from the north poles will have to find its way along leakage paths through air to re-enter the south poles. For periods in each cycle of machine operation the flux will be attracted through the stator cores, but the passage through air is essential and so the power of the magnets is not used to full advantage and there are those unwanted eddy-current effects.

To overcome this problem the invention provides for two separate rotor sections and the stator poles become bridging members, which with optimum design, allow the flux from the magnets to find a route around a magnetic circuit with minimal leakage through air as the flux is directed through one or other pairs of air gaps where the torque action is developed.

Reference is now made to Fig. 5 and the sequence of rotor positions shown. Note that the stator pole width can be significantly smaller than that of the rotor poles. Indeed, for operation using the principles of this invention, it is advantageous for the stator to have a much smaller pole width so as to concentrate the effective pole region. A stator pole width of half that of the rotor is appropriate but it may be even smaller and this has the secondary advantage of requiring smaller magnetizing windings and so saving on the loss associated with the current circuit.

The stator has eight pole pieces formed as bridging members **12**, more clearly represented in Fig. 7, which shows a sectional side view through two rotor sections **13** axially spaced on a rotor shaft **14**. There are four permanent magnets **15** positioned between these rotor sections and located in apertures **16** in a disc **17** of a non-magnetic substance of high tensile strength, the latter being shown in Fig. 6. The rotor sections are formed from disc laminations of electrical steel which has seven large teeth, the salient poles. Magnetizing windings **18** mounted on the bridging members **12** constitute the system governing the action of the motor-generator being described.

The control circuitry is not described as design of such circuitry involves ordinary skill possessed by those involved in the electrical engineering art.

It suffices, therefore, to describe the merits of the structural design configuration of the core elements of the machine. These concern principally the magnetic action and, as can be imagined from Fig. 7, the magnetic flux from the magnets enters the rotor laminations by traversing the planar faces of the laminations and being deflected into the plane of the laminations to pass through one or other of the stator pole bridging members, returning by a similar route through the other rotor.

By using eight stator poles and seven rotor poles, the latter having a pole width equal to half the pole pitch in an angular sense, it will be seen from Fig. 5, that there is always a flux

passage across the small air gap between stator and rotor poles. However, as one pole combination is in-register the diametrically-opposed pole combinations are out-of-register.

As described by reference to Fig. 4 the operation of the machine involves allowing the magnet to pull stator and rotor poles into register and then, as they separate, pulsing the winding on the relevant stator member to demagnetize that member. In the Fig. 4 system, all the stator magnetizing windings were pulsed together, which is not an optimum way in which to drive a multi-pole machine.

In the machine having the pole structure with one less rotor pole than stator poles (or an equivalent design in which there is one less stator pole than rotor poles) this pulsing action can be distributed in its demand on the power supply, and though this makes the commutation switch circuit more expensive the resulting benefit outweighs that cost.

However, there is a feature of this invention by which that problem 15 can be alleviated if not eliminated.

Suppose that the rotor has the position shown in Fig. 5(a) with the rotor pole denoted R_1 midway between stator poles S_1 and S_2 imagine that this is attracted towards the in-register position with stator pole S_2 . Upon reaching that in-register position, as shown in Fig. 5 (c), suppose that the magnetizing winding of stator pole S_2 is excited by a current pulse which is sustained until the rotor reaches the Fig. 5(e) position. The combination of these two actions will have imparted a forward drive impulse powered by the permanent magnet in the rotor structure and the current pulse which suppresses braking action will have drawn a smaller amount of energy from the electrical power source that supplies it. This is the same process as was described by reference to Fig. 4.

However, now consider the events occurring in the rotor action diametrically opposite that just described. In the Fig 5(a) position rotor pole R_4 has come fully into register with stator pole S_5 and so stator pole S_5 is ready to be demagnetized. However, the magnetic coupling between the rotor and stator poles is then at its strongest. Note, however, that in that Fig. 5(a) position R_5 is beginning its separation from stator pole S_6 and the magnetizing winding of stator pole S_6 must then begin draw power to initiate demagnetization. During that following period of pole separation the power from the magnet is pulling R_1 and S_2 together with much more action than is needed to generate that current pulse needed to demagnetize S_6 . It follows, therefore, that, based on the research findings of the regenerative excitation in the test system of Fig. 4, the series connection of the magnetizing windings on stators S_2 and S_6 will, without needing any commutative switching, provide the regenerative power needed for machine operation.

The complementary action of the two magnetizing windings during the pole closure and pole separation allows the construction of a machine which, given that the zero-point vacuum energy powering the ferromagnet is feeding input power, will run on that source of energy and thereby cool the sustaining field system.

There are various design options in implementing what has just been proposed. Much depends upon the intended use of the machine. If it is intended to deliver mechanical power output the regenerative electrical power action can all be used to power the demagnetization

with any surplus contributing to a stronger drive torque by reversing the polarity of the stator poles during pole separation.

If the object is to generate electricity by operating in generator mode then one could design a machine having additional windings on the stator for delivering electrical power output. However, it seems preferable to regard the machine as a motor and maximize its efficiency in that capacity whilst using a mechanical coupling to an alternator of conventional design for the electrical power generation function. In the latter case it would still seem preferable to use the self-excitation feature already described to reduce commutation switching problems.

The question of providing for machine start-up can be addressed by using a separate starter motor powered from an external supply or by providing for current pulsing limited to, say, two stator poles. Thus, for example, with the eight stator pole configuration, the cross-connected magnetizing windings could be limited to three stator pairs, with two stator magnetizing windings left free for connection to a pulsed external supply source.

If the latter feature were not required, then the stator magnetizing windings would all be connected in pairs on a truly diametrically opposite basis. Thus Fig. 8 shows a rotor-stator configuration having six stator poles interacting with seven rotor poles and stator magnetizing windings linked together in pairs.

The invention, therefore, offers a wide range of implementation possibilities, which, in the light of this disclosure will become obvious to persons skilled in the electrical engineering art, all based, however, on the essential but simple principle that a rotor has a set of poles of common polarity which are attracted into register with a set of stator poles that are suppressed or reversed in polarity magnetically during pole separation. The invention, however, also offers the important feature of minimizing commutation and providing further for a magnetic flux closure that minimizes the leakage flux and fluctuations of leakage flux and so contributes to efficiency and high torque performance as well as durability and reliability of a machine incorporating the invention.

It is noted that although a machine has been described which uses two rotor sections it is possible to build a composite version of the machine having several rotor sections. In the eventuality that the invention finds use in very large motor-generator machines the problem of providing very large magnets can be overcome by a design in which numerous small magnets are assembled. The structural concept described by reference to Fig. 6 in providing locating apertures to house the magnets makes this proposal highly feasible. Furthermore, it is possible to replace the magnets by a steel cylinder and provide a solenoid as part of the stator structure and located between the rotor sections. This would set up an axial magnetic field magnetizing the steel cylinder and so polarizing the rotor. However, the power supplied to that solenoid would detract from the power generated and so such a machine would not be as effective as the use of permanent magnets such as are now available. Nevertheless, should one see significant progress in the development of warm superconductor materials, it may become feasible to harness the self-generating motor-generator features of the invention, with its selfcooling properties, by operating the device in an enclosure at low temperatures and replacing the magnets by a superconductive stator-supported solenoid.

CLAIMS

1. An electrodynamic motor-generator machine comprising a stator configured to provide a set of stator poles, a corresponding set of magnetizing windings mounted on the stator pole set, a rotor having two sections each of which has a set of salient pole pieces, the rotor sections being axially spaced along the axis of rotation of the rotor, rotor magnetization means disposed between the two rotor sections arranged to produce a unidirectional magnetic field which magnetically polarizes the rotor poles, whereby the pole faces of one rotor section all have a north polarity and the pole faces of the other rotor section all have a south polarity and electric circuit connections between an electric current source and the stator magnetizing windings arranged to regulate the operation of the machine by admitting current pulses for a duration determined according to the angular position of the rotor, which pulses have a direction tending to oppose the polarization induced in the stator by the rotor polarization as stator and rotor poles separate from an in-register position, whereby the action of the rotor magnetization means provides a reluctance motor drive force to bring stator and rotor poles into register and the action of the stator magnetization windings opposes the counterpart reluctance braking effect as the poles separate.
2. A motor-generator according to claim 1, wherein the circuit connecting the electric current source and the stator magnetizing windings is designed to deliver current pulses which are of sufficient strength and duration to provide demagnetization of the stator poles as the stator and rotor poles separate from an in-register position.
3. A motor-generator according to claim 1, wherein the circuit connecting the electric current source and the stator magnetizing windings is designed to deliver current pulses which are of sufficient strength and duration to provide a reversal of magnetic flux direction in the stator poles as the stator and rotor poles separate from an in-register position, whereby to draw on power supplied from the electric current source to provide additional forward drive torque.
4. A motor-generator according to claim 1, wherein the electric current source connected to a stator magnetizing winding of a first stator pole comprises, at least partially, the electrical pulses induced in the stator magnetizing winding of a different second stator pole, the stator pole set configuration in relation to the rotor pole set configuration being such that the first stator pole is coming into register with a rotor pole as the second stator pole separates from its in-register position with a rotor pole.
5. A motor-generator according to claim 1, wherein the number of poles in a set of stator poles is different from the number of rotor poles in each rotor section.
6. A motor-generator according to claim 1, wherein the stator configuration provides pole pieces which are common to both rotor sections in the sense that when stator and rotor poles are in-register the stator pole pieces constitute bridging members for magnetic flux closure in a magnetic circuit including that of the rotor magnetization means disposed between the two rotor sections.
7. A motor-generator according to claim 6, wherein the number of poles in a set of stator poles and the number of rotor poles in each section do not share a common integer factor and the number of rotor poles in one rotor section is the same as that in the other rotor section.
8. A motor-generator according to claim 7, wherein the number of poles in a stator set and the number of poles in a rotor section differs by one and the pole faces are of sufficient angular width to assure that the magnetic flux produced by the rotor magnetization means can find a

circuital magnetic flux closure route through the bridging path of a stator pole and through corresponding rotor poles for any angular position of the rotor.

9. A motor-generator according to claim 8, wherein each rotor section comprises seven poles.
10. A motor-generator according to claim 7, wherein there are N rotor poles in each rotor section and each has an angular width that is $180/N$ degree of angle.
11. A motor-generator according to claim 7, wherein the stator pole faces have an angular width that is no greater than half the angular width of a rotor pole.
12. A motor-generator according to claim 1, wherein the rotor sections comprise circular steel laminations in which the rotor poles are formed as large teeth at the perimeter, and the rotor magnetization means comprise a magnetic core structure the end faces of which abut two assemblies of 20 such laminations forming the two rotor sections.
13. A motor-generator according to claim 1 in which the rotor magnetization means comprises at least one permanent magnet located with its polarization axis parallel with the rotor axis.
14. A motor-generator according to claim 13, wherein an apertured metal disc that is of a non-magnetizable substance is mounted on a rotor shaft and positioned intermediate the two rotor sections and each aperture provides location for a permanent magnet, whereby the centrifugal forces acting on the permanent magnet as the rotor rotates are absorbed by the stresses set up in the disc.
15. A motor-generator according to claim 1, having a rotor mounted on a shaft that is of a non-magnetizable substance, whereby to minimize magnetic leakage from the rotor magnetizing means.
16. An electrodynamic motor-generator machine comprising a stator configured to provide a set of stator poles, a corresponding set of magnetizing windings mounted on the stator pole set, a rotor having two sections each of which has a set of salient pole pieces, the rotor sections being axially spaced along the axis of rotation of the rotor, rotor magnetization means incorporated in the rotor structure and arranged to polarize the rotor poles, whereby the pole faces of one rotor section all have a north polarity and the pole faces of the other rotor section all have a south polarity and electric circuit connections between an electric current source and the stator magnetizing windings arranged to regulate the operation of the machine by admitting current pulses for a duration determined according to the angular position of the rotor, which pulses have a direction tending to oppose the polarization induced in the stator by the rotor polarization as stator and rotor poles separate from an in-register position, whereby the action of the rotor magnetization means provides a reluctance motor drive force to bring stator and rotor poles into register and the action of the stator magnetization windings opposes the counterpart reluctance braking effect as the poles separate.
17. A motor-generator according to claim 16, wherein the electric current source connected to a stator magnetizing winding of a first stator pole comprises, at least partially, the electrical pulses induced in the stator magnetizing winding of a different second stator pole, the stator pole set configuration in relation to the rotor pole set configuration being such that the first stator pole is coming into register with a rotor pole as the second stator pole separates from its in-register position with a rotor pole.

AMENDMENTS TO THE CLAIMS HAVE BEEN FILED AS FOLLOWS

1. An electrodynamic motor-generator machine comprising a stator configured to provide a set of stator poles, a corresponding set of magnetizing windings mounted on the stator pole set, a rotor having two sections each of which has a set of salient pole pieces, the rotor sections being axially spaced along the axis of rotation of the rotor, rotor magnetization means disposed between the two rotor sections arranged to produce a unidirectional magnetic field which magnetically polarizes the rotor poles, whereby the pole faces of one rotor section all have a north polarity and the pole faces of the other rotor section all have a south polarity and electric circuit connections between an electric current source and the stator magnetizing windings arranged to regulate the operation of the machine by admitting current pulses for a duration determined according to the angular position of the rotor, which pulses have a direction tending to oppose the polarization induced in the stator by the rotor polarization as stator and rotor poles separate from an in-register position, whereby the action of the rotor magnetization means provides a reluctance motor drive force to bring stator and rotor poles into register and the action of the stator magnetization windings opposes the counterpart reluctance braking effect as the poles separate, the machine being characterized in that the stator comprises separate ferromagnetic bridging members mounted parallel with the rotor axis, the ends of which constitute stator poles and the core sections of which provide cross-section disposed antiparallel with the unidirectional magnetic field polarization axis of the rotor magnetizing means.
2. A motor-generator according to claim 1, wherein the circuit connecting the electric current source and the stator magnetizing windings is designed to deliver current pulses which are of sufficient strength and duration to provide demagnetization of the stator poles as the stator and rotor poles separate from an in-register position.
3. A motor-generator according to claim 1, wherein the circuit connecting the electric current source and the stator magnetizing windings is designed to deliver current pulses which are of sufficient strength and duration to provide a reversal of magnetic flux direction in the stator poles as the stator and rotor poles separate from an in-register position, whereby to draw on power supplied from the electric current source to provide additional forward drive torque.
4. A motor-generator according to claim 1, wherein the electric current source connected to a stator magnetizing winding of a first stator pole comprises, at least partially, the electrical pulses induced in the stator magnetizing winding of a different second stator pole, the stator pole set configuration in relation to the rotor pole set configuration being such that the first stator pole is coming into register with a rotor pole as the second stator pole separates from its in-register position with a rotor pole.
5. A motor-generator according to claim 1, wherein the number of poles in a set of stator poles is different from the number of rotor poles in each rotor section.
6. A motor-generator according to claim 1, wherein the stator configuration provides pole pieces which are common to both rotor sections in the sense that when stator and rotor poles are in-register the stator pole pieces constitute bridging members for magnetic flux closure in a magnetic circuit including that of the rotor magnetization means disposed between the two rotor sections.

7. A motor-generator according to claim 6, wherein the number of poles in a set of stator poles and the number of rotor poles in each section do not share a common integer factor and the number of rotor poles in one rotor section is the same as that in the other rotor section.

Search Examiner:

J. COCKITT

Categories of documents

X: Document indicating lack of novelty or of inventive step.

A: Document indicating technological background and/or state of the art.

Category	Identity of document and relevant passages	Relevant to claim(s)
X	GB 0547668 (HITCHCOCK) see page 6 lines 54 to 71; Figures 6, 7	1-3, 6, 12-14, 16 at least
X	US 4972112 (KIM) see whole document	1-3 at least
A	US 4873463 (JONES)	
