

**DESIGNING
YOUR OWN
HEAD ASSEMBLY
GUIDE**

**FOR
SmartPAK™ Systems**

VERSION 2.0

INTALEK, INC.

3506-43rd. Place
Highland, IN
46322

CONTACT INFO:

PHONE: 219.924.2742

EMAIL: info@intalek.com

Disclaimer: The author assumes no liability for any incidental, consequential or other liability from the use of this information. All risks and damages, incidental or otherwise, arising from the use or misuse of the information contained herein are entirely the responsibility of the user. The author assumes no responsibility for any omissions or errors in the diagrams or measurement data published in this document.

The diagrams published are currently, or have been under test by the author, and may be subject to modification after they have been published in this document.

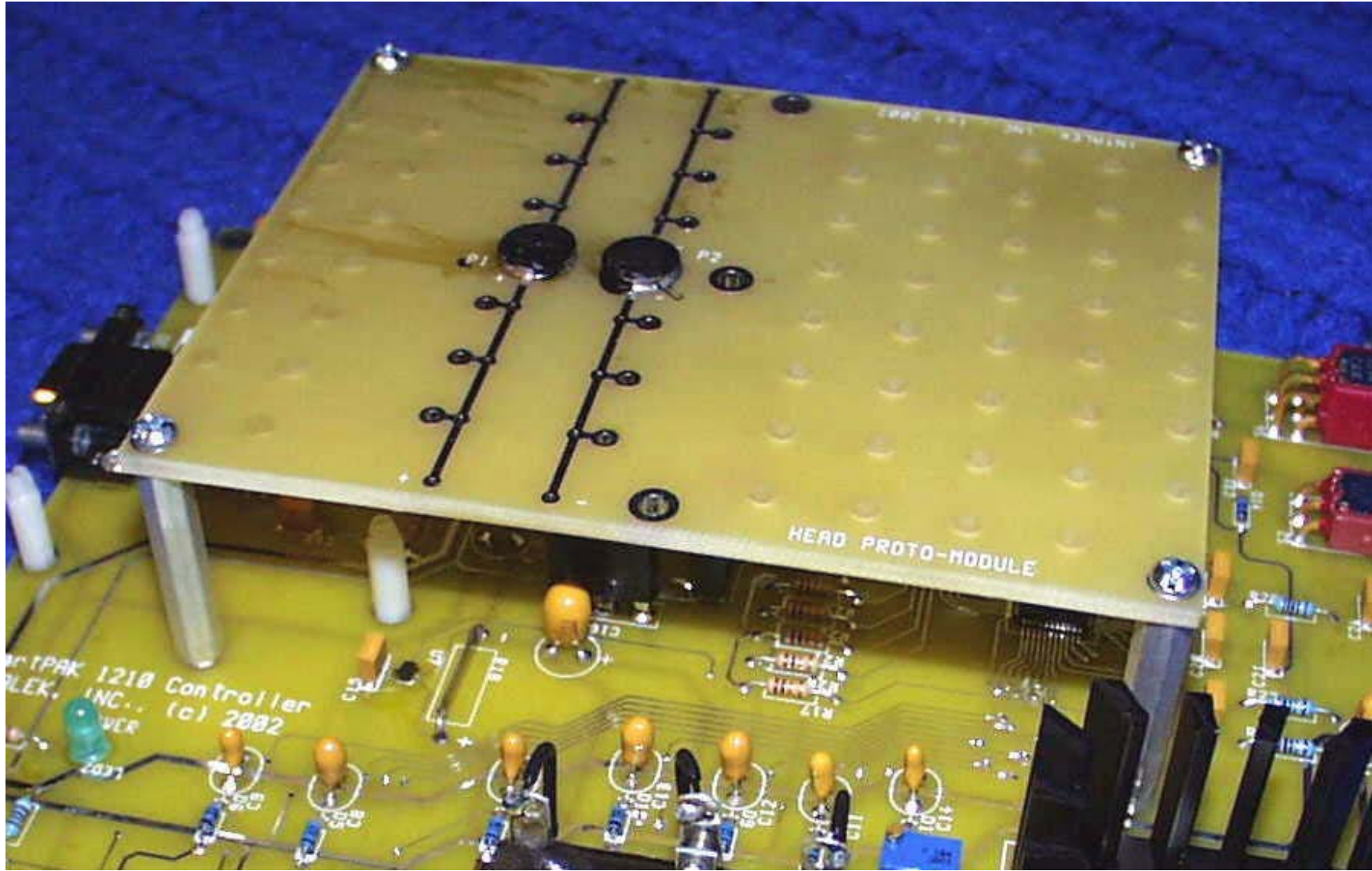

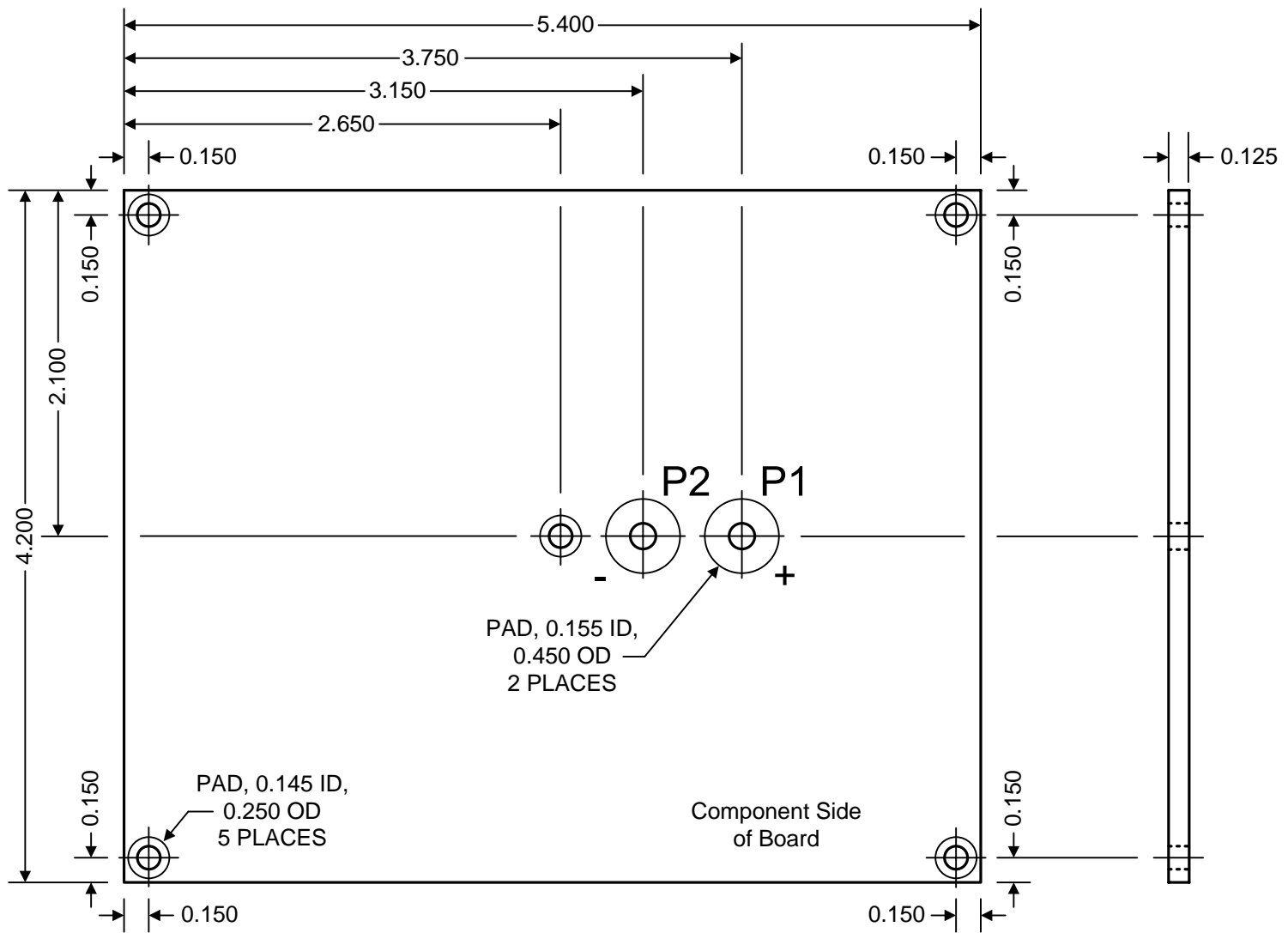

MATERIAL: FR-4 (G10)
 All dimensions are in inches.

*NOTE: Inner diameter specified is after plating.
 For #6-32 screw.

STEP 1: Fix rivet to plug, P1 and P2.

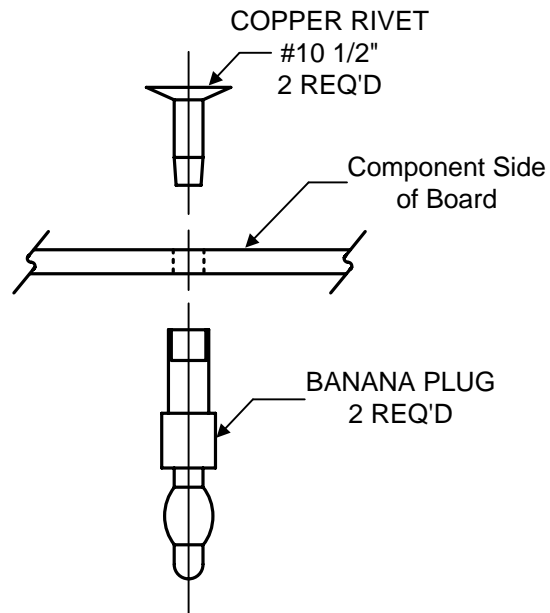

STEP 2: Apply solder. Allow to cool. Then, fix heat shrink tubing.

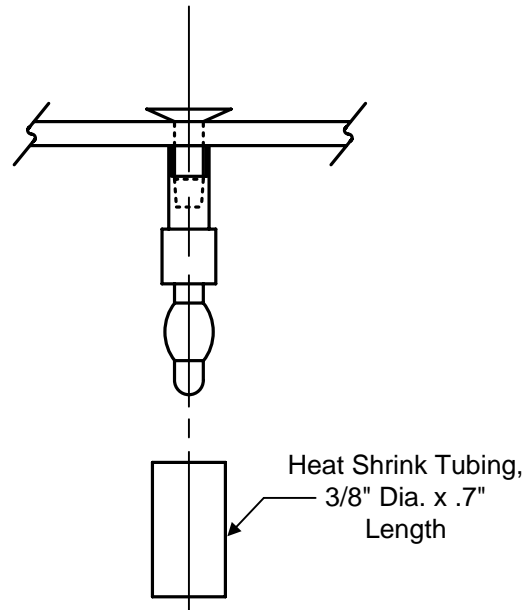

STEP 3: Apply rubber sealant. Allow to dry.

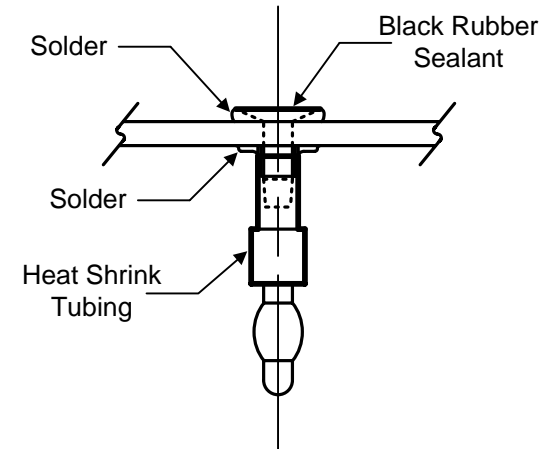

***PARTS:**

1. Copper Rivet - #10 1/2", Sears, Ace Hardware.
2. Banana Plug, Radio Shack 278-321.
3. Heat Shrink Tubing, 3/8" Dia. x .7" Length, Home Depot (Buchanan) 73804 .
4. Black Rubber Sealant, Sears, (Loctite) 80236

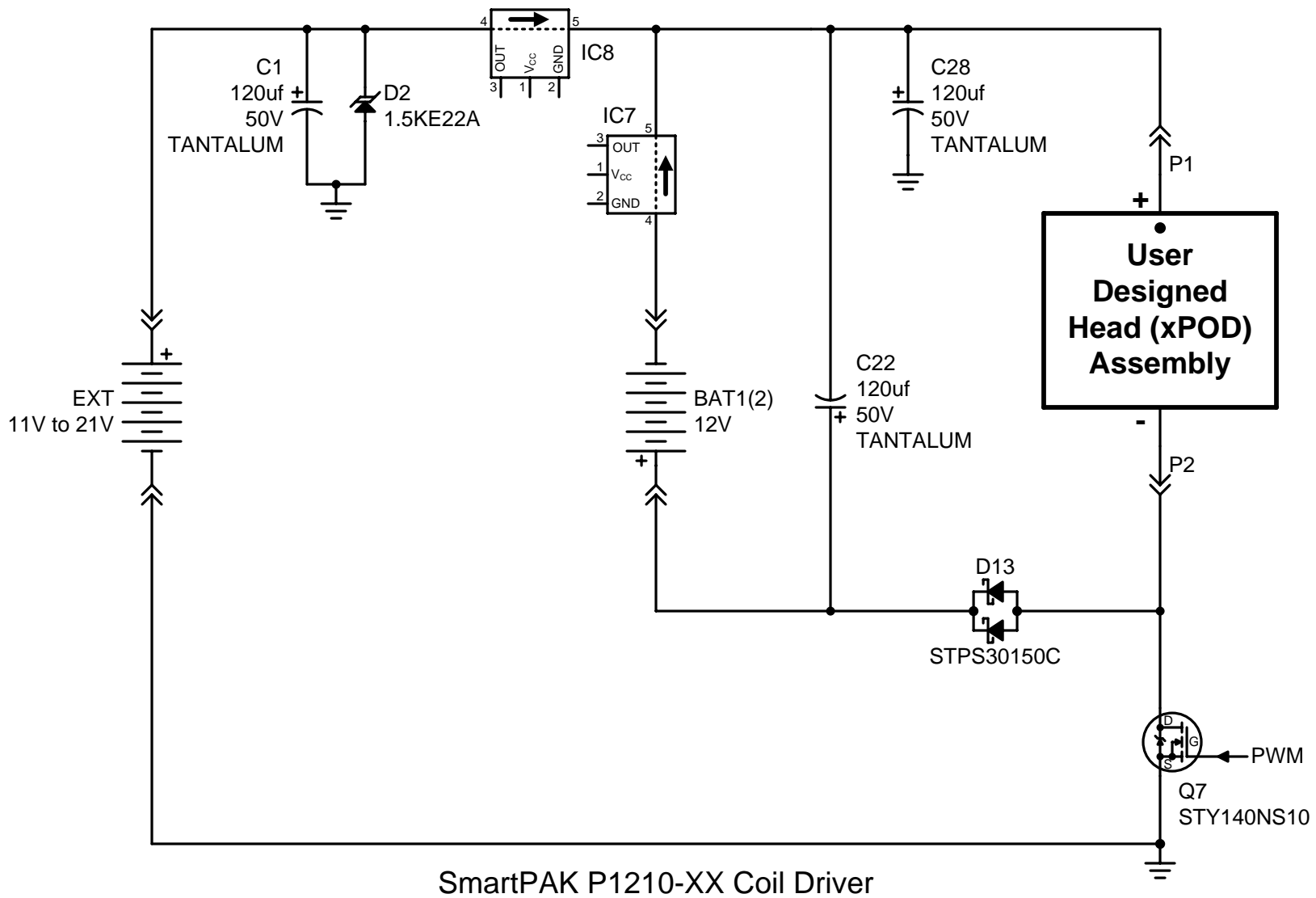

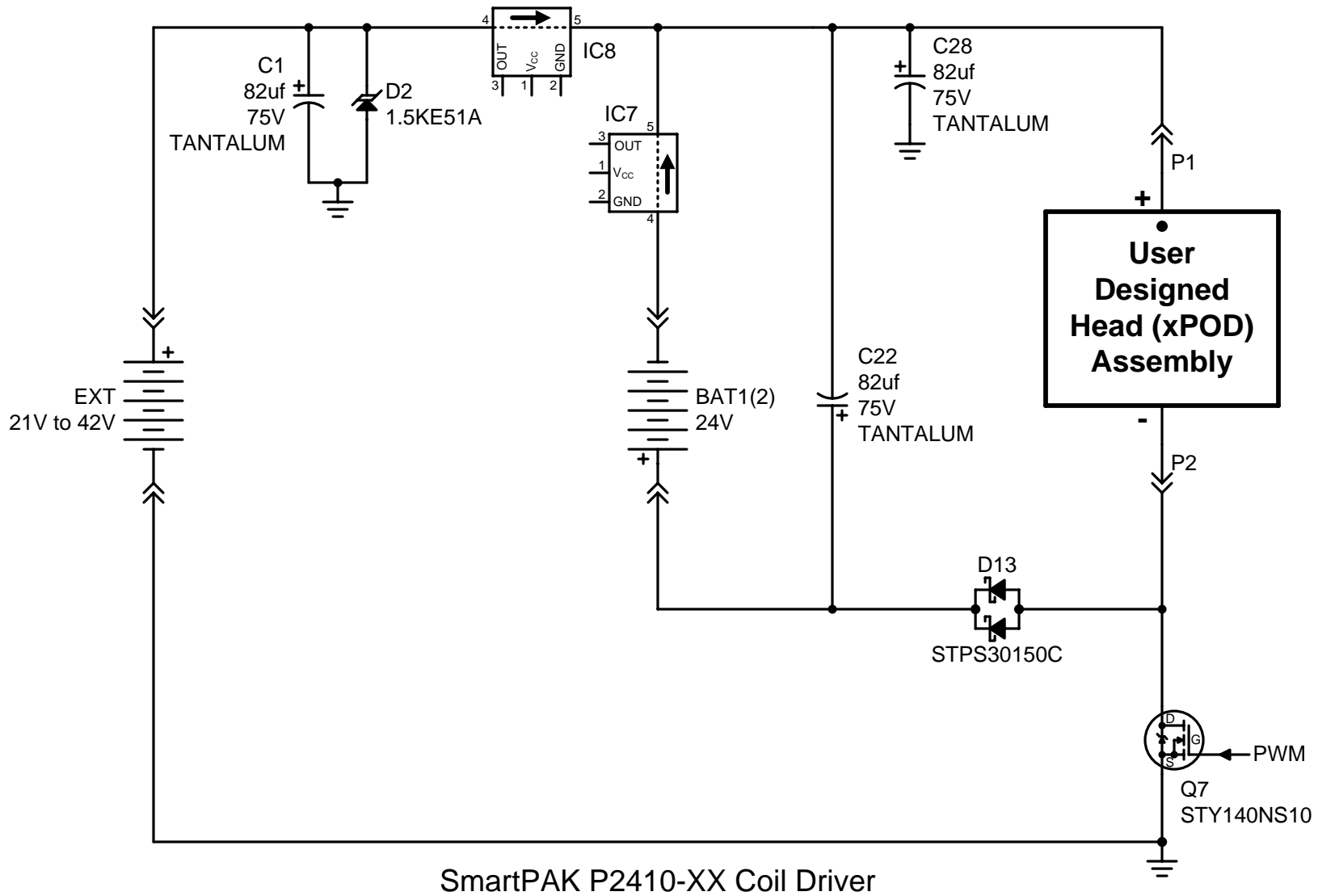

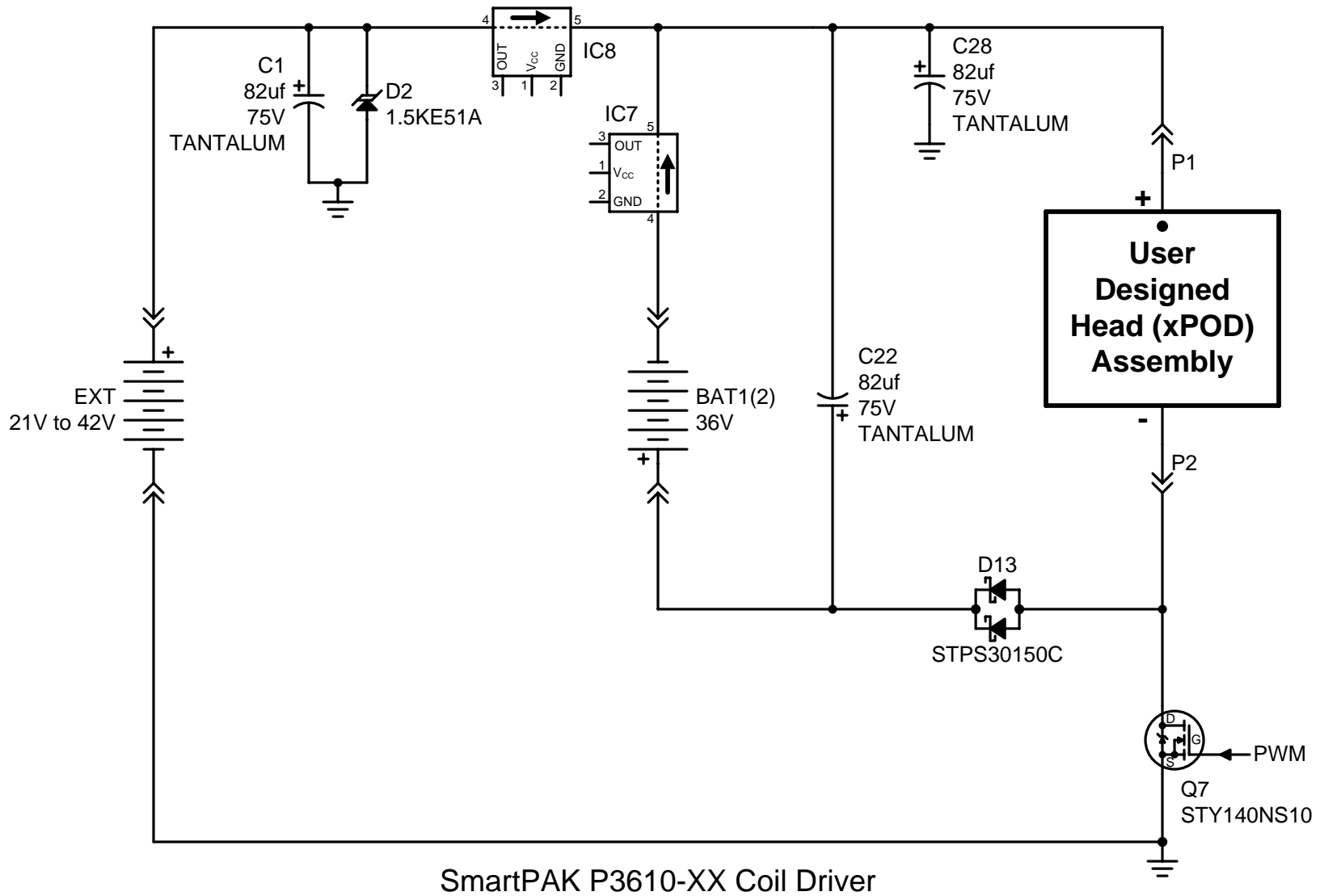

SmartPAK P3610-XX Coil Driver

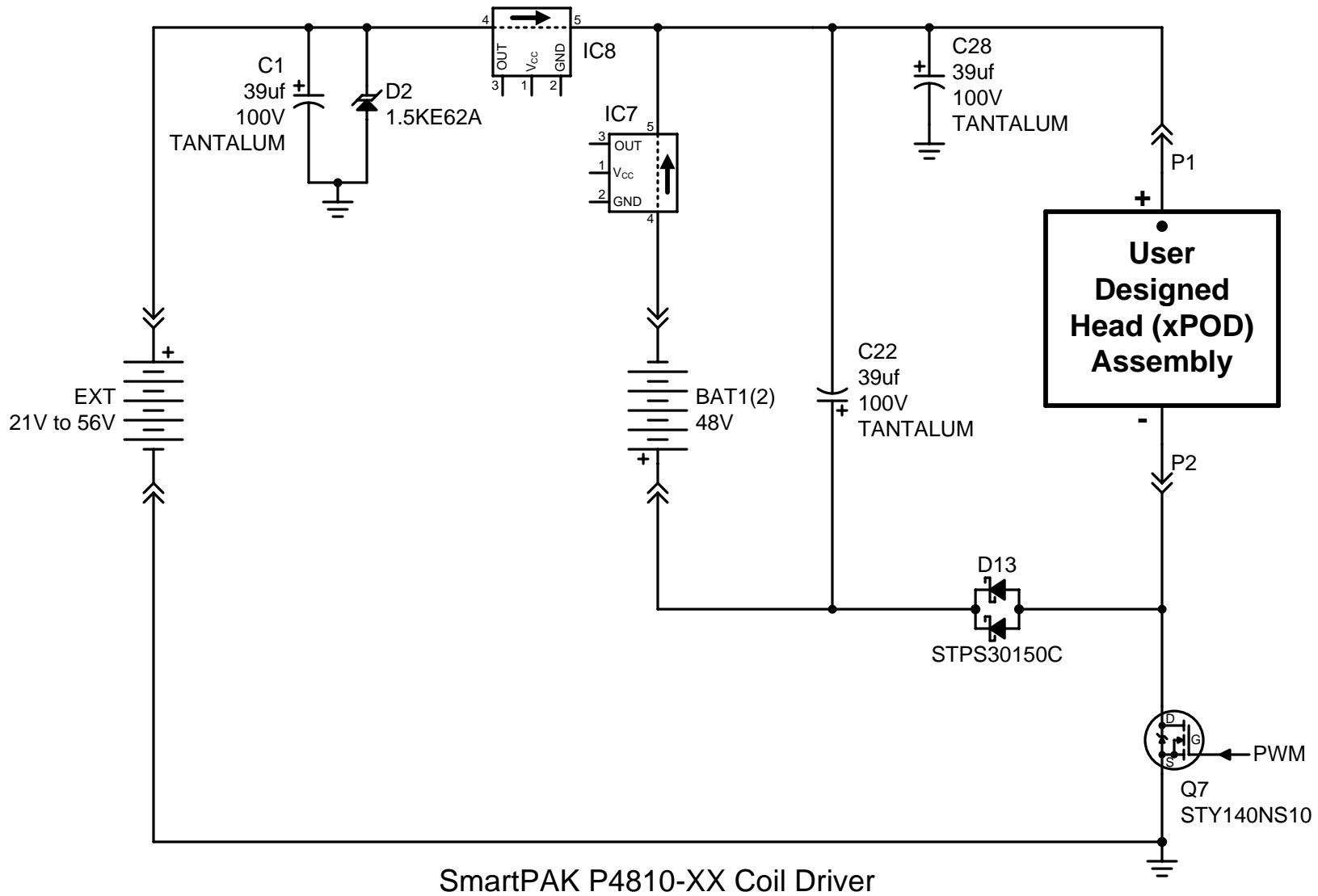

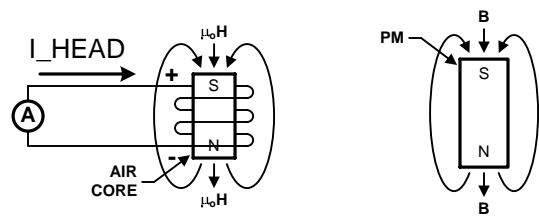
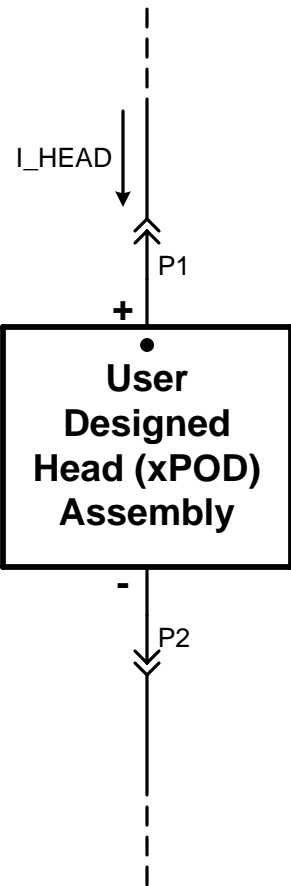

NOTE:
Field directions of coils and magnets: